

## Non-Contact Based Baby Monitoring

<sup>1</sup>Ankita Kawale, <sup>2</sup>Indrayani Deshmukh, <sup>3</sup>Monika Hakande, <sup>4</sup>Payal Raut.

<sup>1</sup>Student, Yeshwantraochavan College Of Engineering, Hingna Road, Wanadongri, Nagpur-441110

---

**Abstract:** We propose our project of non-contact based baby monitoring system. This system is use for proper safety and controlling of baby by their busy parents. It can detect the motion, crying and the present position of the baby, if the baby is near to an edge of the bed then the system will send a message in the form of images to the particular user through an email. Here we have used RPi 3 B+ module for overall control of hardware, MIC for crying detection and also used DIP for detection of real-time motion of babies and boundary condition of the bed. This system will help to decrease the chances of the baby's falling from the bed. Also, this system might be use in hospitals while baby is sleeping where the stress among the nurses will reduce.

**Index Terms:** Baby Monitoring System, DIP(Digital Image Processing), Pi Camera, GPIO, RPi(Raspberry Pi)

---

### I. Introduction

In India, both the parents need to work and look after their babies, so more workload and stress is there in such families, especially on female counterparts. In order to face this, a Non-contact based Baby Monitoring system using image processing might be developed which would help the parents to monitor their babies with the help of received data via email. Image processing is use to analyze and manipulate the images with the help of a computer. Also this technology is a library of programming functions mainly aimed at a real-time computer vision.

We have used Raspberry pi 3B+ which is a full-fledged credit card sized computer which has a faster 64-bit 1.4 GHz quad-core processor and 1GB RAM.

### II. Literature Review

The objective and motivation towards this work stated above as well as it consists of certain conference papers and case studies. The baby monitoring system is introduce in [1] by Aslam Forhad Symon, Nazia Hassan and Humayun Rashid consists use of Raspberry Pi B+ module, condenser MIC to detect baby's crying condition and PIR sensor to detect it movement along with a Pi camera to capture baby's motion. A display is attach to the system to have the video output along with the sound of the baby. A real-time baby monitoring system based on RPi and Beacon technology using android app is introduced in [2] by Rameesa. O, Prof. C Periasamy and Ms. Priyanka. M. T. includes RPi and a Pi camera in order to capture real-time video to develop a web-based system where Python and PHP software are use. The system used to provide the security and safety in monitoring their children remotely, Also in [3]presented by Shreelatha, Shreya Pai, Sonal Cynthia Pereira, Tanya Nicole, Ms Ushadevi A.in which their system provides feature in order to help parents in the process of parenting and make this process simpler and much easier. This system can detect the baby's motion and sound and automatically send out emergency signal.

### III. Methodology

The proposed system is about monitoring the activities of baby remotely. It mainly consists of sensor, hardware unit, cloud server and parent's application. The Fig. 1.shows how these all element interact with each other.

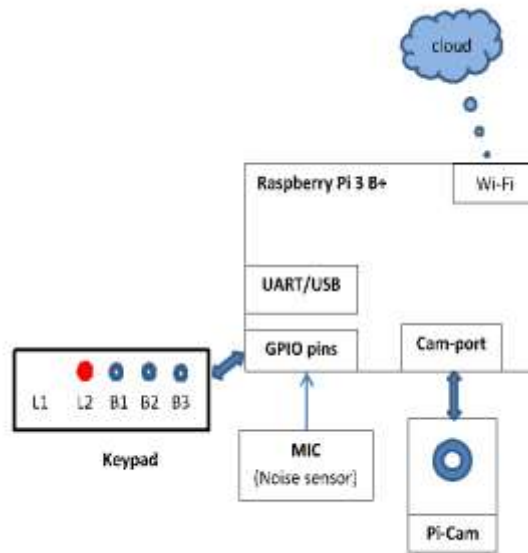

**Fig. 1.**System Block Diagram

The system as shown in the Fig. 1 based around an internet enabled single board computer called Raspberry Pi 3 B+. All the peripherals interfaced with RPi module are either connected wired or wirelessly. The RPi module shall be used in headless configuration, i.e., without keyboard, mouse or monitor connected to it. A separate keypad consisting of three buttons and one LED shall be interfaced with GPIO pins of RPi module.

L1-Acknowledgment LED, L2-indicator for internet availability, B1-Shutdown B2-Restart, B3-Acknowledgement button. Pi Cam is use to figure-out the baby’s position on the bed(whether it’s near the edge or not ), by implementing DIP techniques through OpenCV library. A noise sensor shall be interfaced to trigger the Pi-cam and deduce if the baby is crying. The RPi module will send data about the baby’s well-being periodically, through emails to the registered users. Also, occasionally, snaps of the baby will send to the user on request. The system program shall be written in python language, which will begin executing on its own as soon as the system shall be powered up.

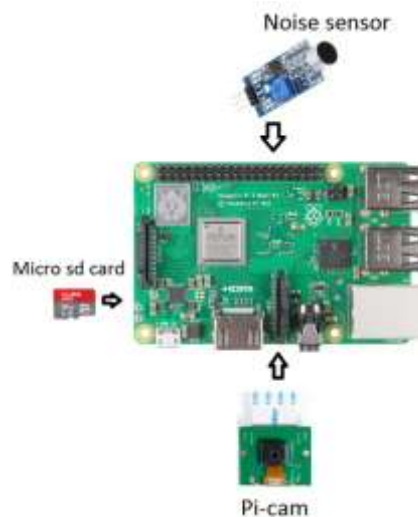

**Fig.2:** Hardware Arrangement of the system

Condenser MIC as in Fig.2. is use in this project to detect the baby’s crying and it provides a signal to RPi. This system also consist of a Pi Camera module used for taking HD video output of the baby’s present position. It works in a network of cloud in which message of alert with snap of baby’s current position send a to particular registered user. The ribbon cord of Pi Camera is inserting into camera slot to attach the Pi Camera of RPi.

### IV. Circuit Implementation

The Fig. 3.shows the connection details, in which the acknowledgement button is connects to pin 36 which is 16th number GPIO pin by pressing this button we able to know system is working or not for this acknowledgement led is connects to pin 40 of Rpi which glows when the system is working. Warning led is connects to pin 38 i.e. 20 number GPIO pin which glows when system detects the abnormal condition. Restart button is connects to pin 32 i.e. 12th number GPIO pin which is use to restart the Rpi headlessly. Now the shutdown button is connects to pin 33 i.e. 13th number GPIO pin to shutdown RPi headlessly. Condenser MIC output is connects to pin 8 i.e. 14th GPIO pin which is use to detect the noise.

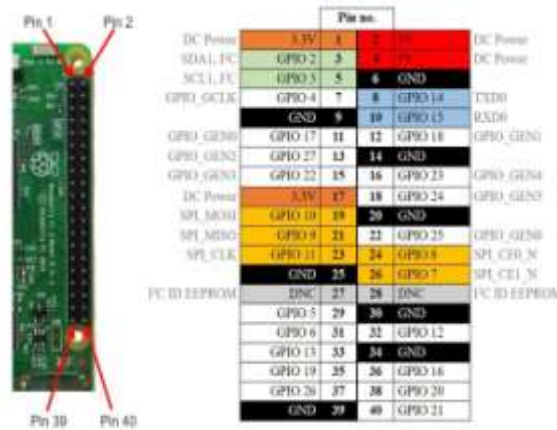

Fig. 3.GPIO Pins Connection

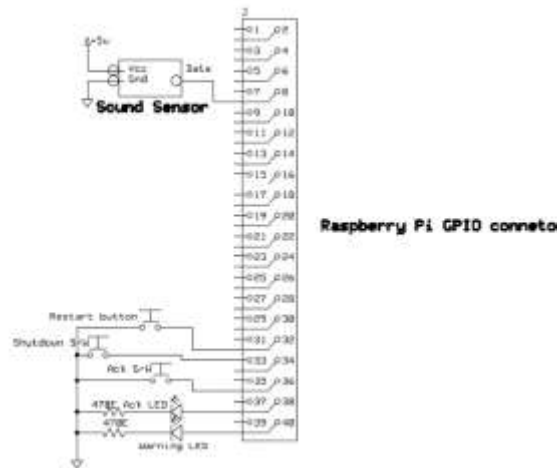

Fig.4.Circuit diagram of system

### V. Software Development

At First, we have Installed latest version of Raspbian OS using NOOBS method and then the Package installations is done.

- 1) The first step is to update and upgrade any existing package.
- 2) install pip (Python package manager)
- 3) Installing virtual environment on RPi module.

The Programming language which is applied to configure RPi is python after installing the Raspbian OS in an SD card .RPi uses Pi camera, library files of Pi camera have been installed, after RPi is power up, it will initialize the python script. If any crying is detects, RPi will send a signal to Pi camera and RPi will collect information of the baby’s present condition. Also the boundary detection is done by taking in consideration the dimensions of the bed on which the baby is sleeping and if the baby moves beyond the particular boundary then the alert message with snap will send to the users.

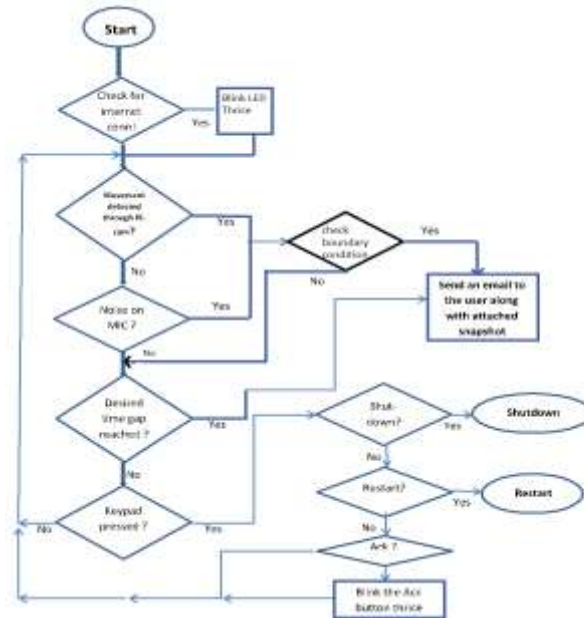

Figure. 5. Program Flowchart

### VI. Result Analysis

The Raspberry Pi camera is set up in such a way that it can capture the doll’s face and body correctly. Image processing is used to detect the baby’s movement after detecting the movement or baby is near the edge of bed the Pi camera triggers, it will click the snap and send alert to the parents through mail. Condenser MIC is used to detect the baby’s crying voice. When the baby is sleeping, there is no crying, so no voice detected by MIC and that’s why there is no output. When baby is awake and starts crying it means that MIC receives an input signal from baby and sends it to RPi module. Raspberry Pi receives a high signal, it means baby is crying. RPi activates the pi camera and sends alert mail to parents. We are making Raspberry-pi headless, so we are providing a keypad to operate RPi. Shut down button is used to shutdown RPi headlessly, Restart button is used to restart RPi, Acknowledgement button is used to know system is working or not which we can see through ack (Acknowledgement) led.

We have made our own Haar cascade classifier for the doll shown in the Fig 7. by collection of positive and negative images in the ratio of 1:10. Marking positive images using objectmarker.exe or Image clipper tools. Created a vector file based on positive marked images using createsamples.exe. Training the classifier using haartraining.exe and running the classifier using cvHaarDetectObjects().



Fig. 6. Motion Detection



Fig. 7.Sound Detection



Fig. 8.Boundary Detection



Fig. 9.Setup of the baby monitoring system

We are sending the email at the desire time interval of 120 sec where the detection of the crying and the present position be judged and when the baby reaches to the boundary of the bed , the alert will send to parent's with the snap of the baby. The Final output as shown in Fig. 9. replicates that the alert in the form of mail is send to the parent's email which shows the current position of the baby and if they find something wrong like baby reaches to the edge of the bed then proper action might be taken by them.

## VII. Conclusion

An automatic non-contact based baby monitoring system which uses Image processing is the best solution for parents to monitor their babies even in busy schedule. Our aim is to develop a non-contact based system which will provide a high level of baby's security. This system sends the message to parents through mail when abnormal condition occurs. The main advantage of this is that it is more user friendly, cost-effective

and no harm to baby as it is non-contact based baby monitoring system. It might be used in hospitals by the nurses to monitor the baby. We used RPi module as it provides more advantage comparatively to the Arduino and Microcontroller. It can detect whether the baby is sleeping or awake. This system will help in decreasing the chances of the baby's falling from the bed. Thus, the safety issue of baby is also confirmed in this system. Although this system is implement, further improvement of the system might be done.

### **Acknowledgement**

We would like to thank Dr. Y. K. Dubey (Chitriv) for her expert advice and encouragement throughout this difficult project .

### **References**

- [1]. Design and Development of a Smart Baby Monitoring System based on Raspberry Pi and Pi Camera. Conference Paper:September 2017 DOI: 10.1109/ICAEE.2017.8255338
- [2]. REAL TIME CHILD MONITORING SYSTEM BASED ON RASPBERRY PI AND BEACON TECHNOLOGY USING ANDROID APP.ISSN:2320-5407 Int. J. Adv. Res.6(3),1410-1416
- [3]. Advanced Baby Monitor International Journal of Internet of Things2017,6(2):51-55DOI: 10.5923/j.ijit.20170602.09
- [4]. S. Brangui, M. El Kihal and Y. Salih-Alj, "An enhanced noise cancelling system for a comprehensive monitoring and control of baby environments", 2015 International Conference on Electrical and Information Technologies (ICEIT), pp. 404-409, 2015.
- [5]. Object recognition using the OpenCVHaar cascade-classifier on the iOSplatformInstitutionenförinformationsteknologi, IT 13 007 Examensarbete 15 hpJanuari 2013
- [6]. LIVE VIDEO STREAMING SYSTEM USING RASPBERRY PI WITH CLOUD SERVER, ISSN 2348 – 9928 IJAICT Volume 2, Issue 11, March 2016 Doi:01.0401/ijaict.2016.11.01 Published on 05 (04) 2016
- [7]. [http://docs.opencv.org/doc/tutorials/introduction/tableof\\_content](http://docs.opencv.org/doc/tutorials/introduction/tableof_content)